

### PR-K40D15

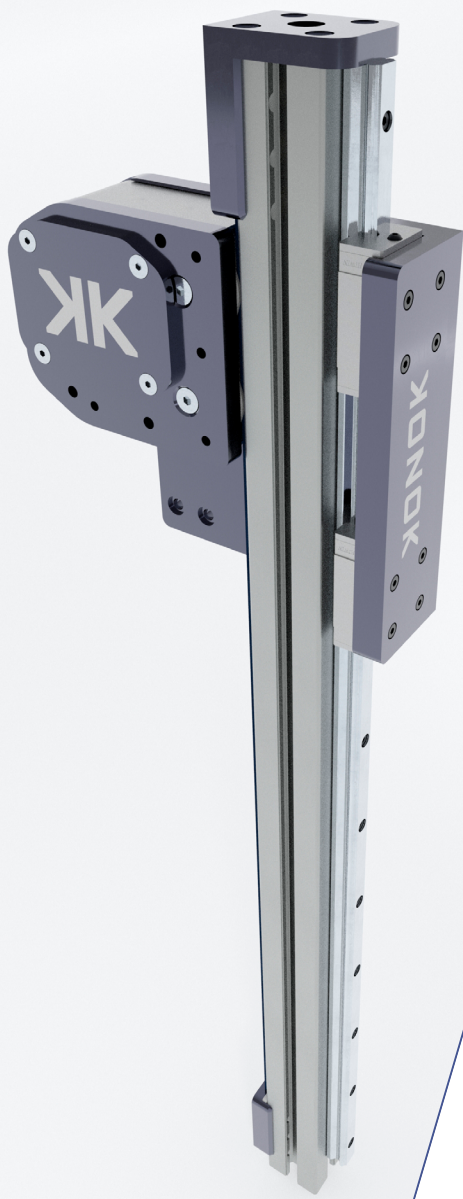

#### SPECIFICHE TECNICHE / TECHNICAL DATA

Versione unità Type Unit	Monoguida verticale Vertical monorail
Sezione portante Structure Section	40x40
Dimensioni guide Rail Size	15
Cinghia Belt	AT5-25
Velocità Speed	4 (m/sec)
Accelerazione Acceleration	30 (m/sec <sup>2</sup> )
Ripetibilità Repeatability	0.1 (mm)

#### DATI PULEGGIA / PULLEY DATA

Puleggia Pulley	Z30
Ø Primitivo puleggia Ø Pulley Primitive	47.76 [mm]
Passo per giro puleggia Step for Pulley turn	150 [mm]
Coppia a vuoto Starting Torque	2.0 [Nm]

#### PESI / WEIGHTS

Modulo corsa zero Module zero travel	4.1 kg
Peso barra corsa zero Zero stroke bar weight	1.6 kg
Peso 100mm lineare Linear weight 100mm	0.36 kg
Peso del carro Carriage weight	2.5 kg

#### CONDIZIONI DI ESERCIZIO CONSIGLIATE / RECOMMENDED OPERATING CONDITIONS

Momento dinamico Dynamic Moment	<b>Mx</b> 26 Nm	<b>My</b> 210 Nm	<b>Mz</b> 210 Nm
Forze statiche Static forces	<b>Fy</b> 1138 N	<b>Fz</b> 1138 N	
Carico a trazione Tensile load	<b>Fx</b> 800 N		

\* Il valore Fx si riferisce al carico applicabile alla puleggia, e non al valore di carico ammissibile dalla cinghia. Tale valore è calcolato sulla base del tipo di cinghia e del numero di denti della puleggia.  
\* The Fx value refers to the load applicable to the pulley, and not to the allowable load value of the belt. This value is calculated on the basis of the type of belt and the number of pulley teeth.

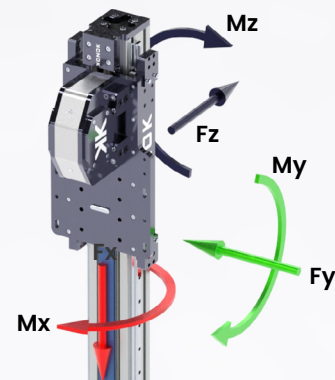

I valori dinamici indicati non corrispondono alle massime capacità di carico teoriche. Sono stati calcolati considerando fattori di sicurezza adatti alle automazioni industriali. In caso di sollecitazioni massime contemporanee si prega di contattare il servizio tecnico.  
The dynamic values indicated do not correspond to the theoretical maximum load capacities. They have been calculated considering safety factors suitable for industrial automation. In case of simultaneous maximum stresses, please contact the technical service.

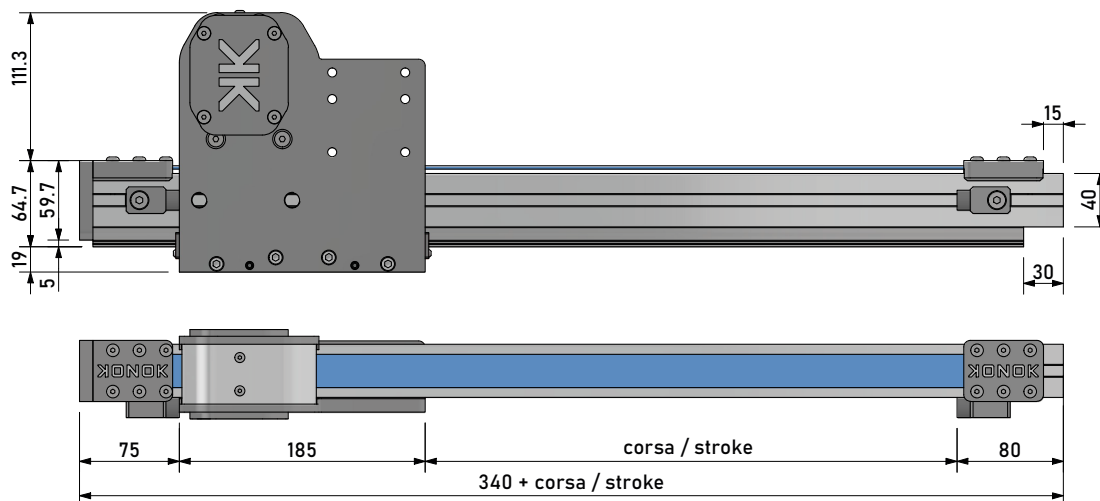

PAG. 151

### SEZIONE PORTANTE / STRUCTURAL SECTION

Momento d'inerzia Moment of inertia	$I_x$	$12.0 \text{ cm}^4$
Momento d'inerzia Moment of inertia	$I_y$	$12.0 \text{ cm}^4$
Modulo resistenza flessione Flexural Modulus	$W_x$	$6.0 \text{ cm}^4$
Modulo resistenza flessione Flexural Modulus	$W_y$	$6.0 \text{ cm}^4$
Peso lineare Linear Weight		$2.0 \text{ Kg/m}$
Tipo cava Hollow Type		08-PK

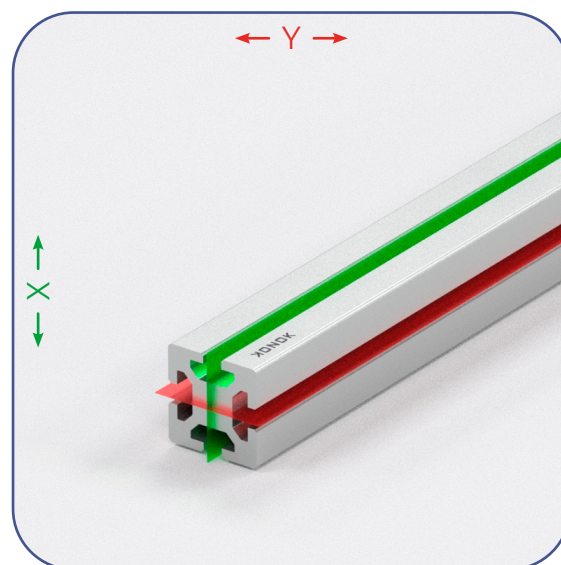

# PR-K40D15

### DIMENSIONI / DIMENSIONS

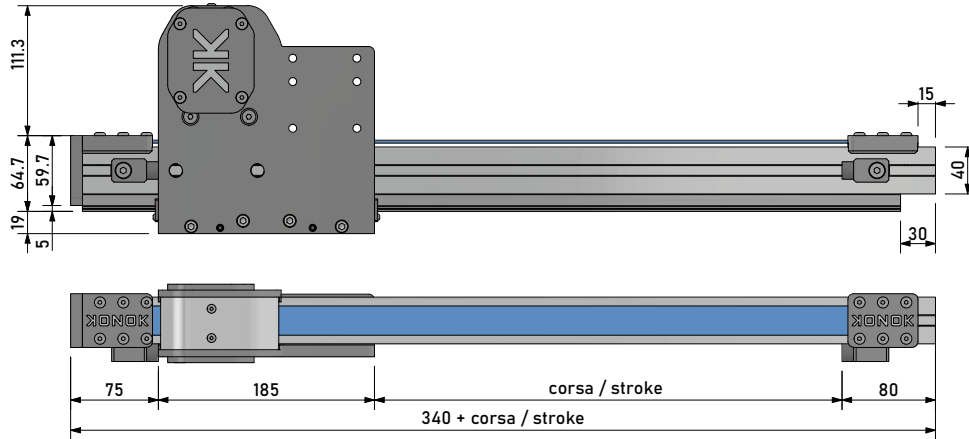

### DIMENSIONI CARRO / CARRIAGE DIMENSIONS

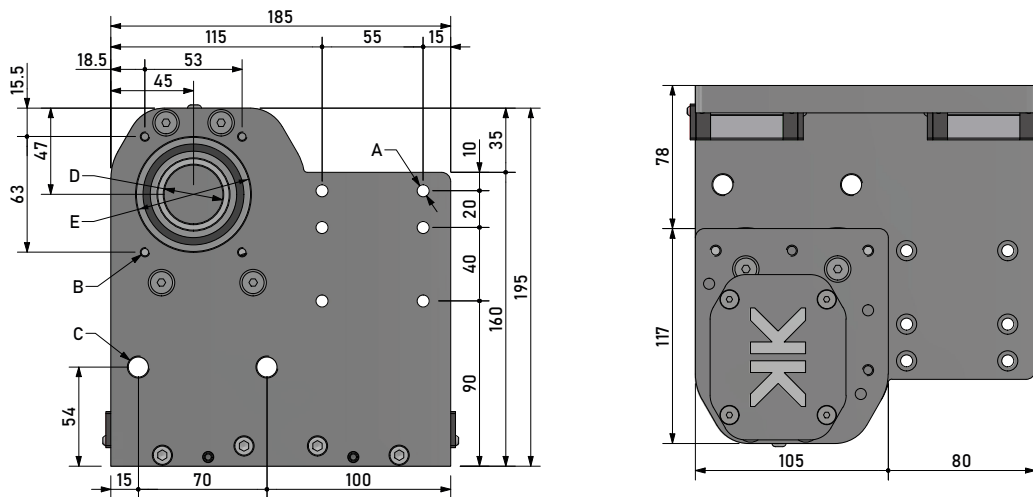

### DIMENSIONI TESTATA MOTORE / MOTOR HEAD DIMENSIONS

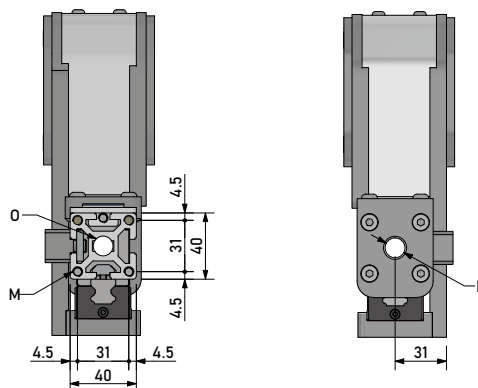

NOME / NAME	A	B	C	D	E	M	N	O
Ø - FILETTO / Ø - THREAD	6x Ø6.6	4x M5	2x M12	Ø32 H7	Ø62 h7	4x M6	Ø12	Ø12 a scelta M8
PROFONDITÀ / DEPTH	PASSANTE / THRU-HOLE	10	PASSANTE / THRU-HOLE	PASSANTE / THRU-HOLE	/	10	PASSANTE / THRU-HOLE	Ø8 M8 prof. 20
SPORGENZA / SPORGENZA	/	/	/		2	/	/	/