

### HU-M160L20

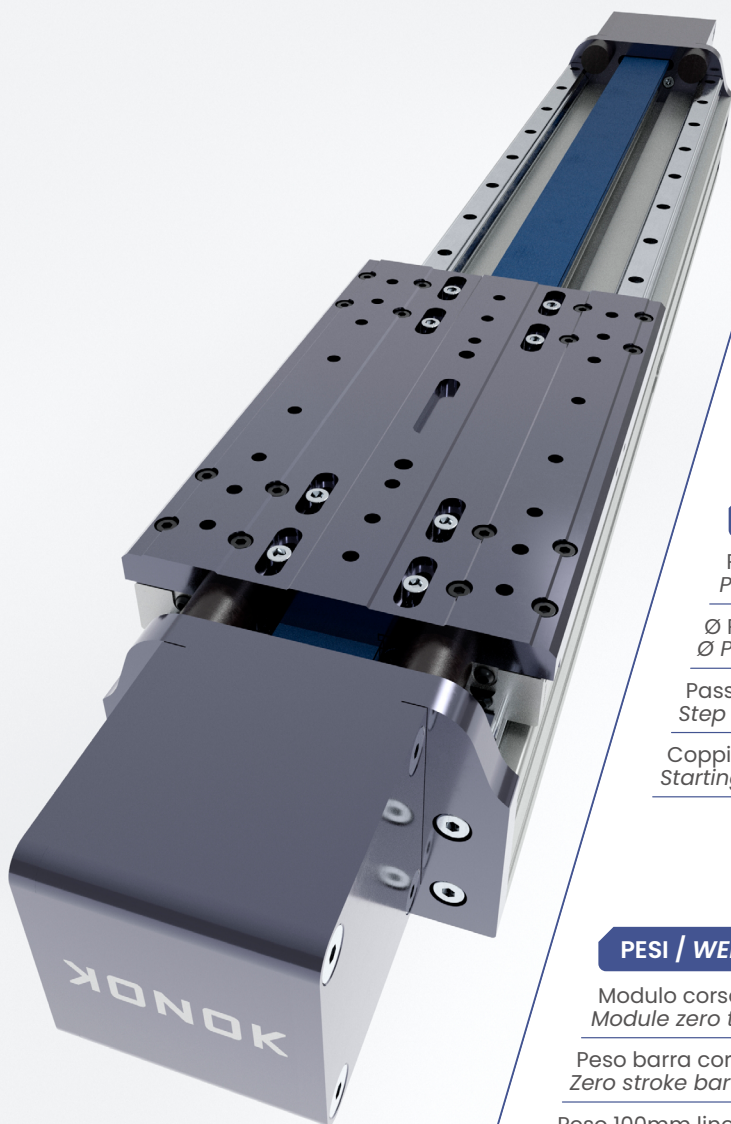

#### SPECIFICHE TECNICHE / TECHNICAL DATA

Versione unità Type Unit	Doppia guida Double guide
Sezione portante Structure Section	80x160
Dimensioni guide Rail Size	20
Cinghia Belt	AT10-40
Velocità Speed	4 (m/sec)
Accelerazione Acceleration	30 (m/sec <sup>2</sup> )
Ripetibilità Repeatability	0.1 (mm)

#### DATI PULEGGIA / PULLEY DATA

Puleggia Pulley	Z22
Ø Primitivo puleggia Ø Pulley Primitive	70.03 [mm]
Passo per giro puleggia Step for Pulley turn	220 [mm]
Coppia a vuoto Starting Torque	3.0 [Nm]

#### PESI / WEIGHTS

Modulo corsa zero Module zero travel	15.7 kg
Peso barra corsa zero Zero stroke bar weight	-- kg
Peso 100mm lineare Linear weight 100mm	1.72 kg
Peso del carro Carriage weight	4 kg

#### CONDIZIONI DI ESERCIZIO CONSIGLIATE / RECOMMENDED OPERATING CONDITIONS

Momento dinamico Dynamic Moment	<b>Mx</b> 790 Nm	<b>My</b> 1340 Nm	<b>Mz</b> 1550 Nm
Forze statiche Static forces	<b>Fy</b> 4610 N	<b>Fz</b> 4610 N	
Carico a trazione Tensile load	<b>Fx</b> 2600 N		

\* Il valore Fx si riferisce al carico applicabile alla puleggia, e non al valore di carico ammissibile dalla cinghia. Tale valore è calcolato sulla base del tipo di cinghia e del numero di denti della puleggia.  
\* The Fx value refers to the load applicable to the pulley, and not to the allowable load value of the belt. This value is calculated on the basis of the type of belt and the number of pulley teeth.

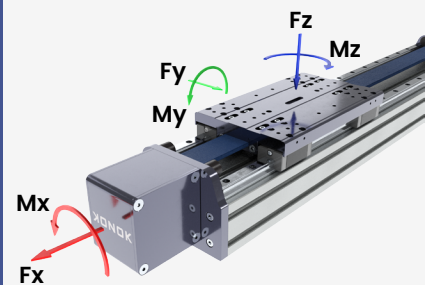

I valori dinamici indicati non corrispondono alle massime capacità di carico teoriche. Sono stati calcolati considerando fattori di sicurezza adatti alle automazioni industriali. In caso di sollecitazioni massime contemporanee si prega di contattare il servizio tecnico.  
The dynamic values indicated do not correspond to the theoretical maximum load capacities. They have been calculated considering safety factors suitable for industrial automation. In case of simultaneous maximum stresses, please contact the technical service.

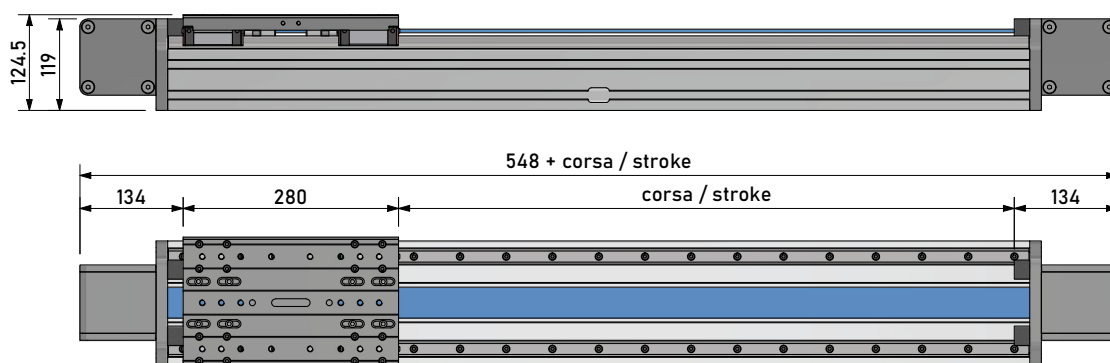

PAG. 138

### SEZIONE PORTANTE / STRUCTURAL SECTION

Momento d'inertzia <i>Moment of inertia</i>	$I_x$	$287.5 \text{ cm}^4$
Momento d'inertzia <i>Moment of inertia</i>	$I_y$	$975.5 \text{ cm}^4$
Modulo resistenza flessione <i>Flexural Modulus</i>	$W_x$	$71.9 \text{ cm}^4$
Modulo resistenza flessione <i>Flexural Modulus</i>	$W_y$	$121.9 \text{ cm}^4$
Peso lineare <i>Linear Weight</i>		$10.4 \text{ Kg/m}$
Tipo cava <i>Hollow Type</i>		10-PG

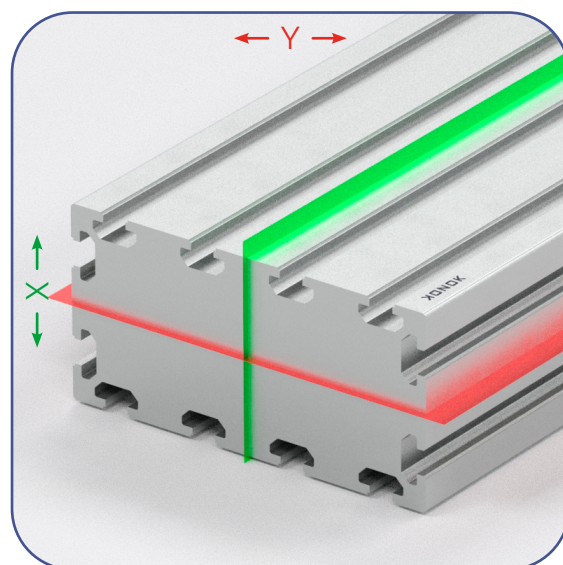

# HU-M160L20

### DIMENSIONI / DIMENSIONS

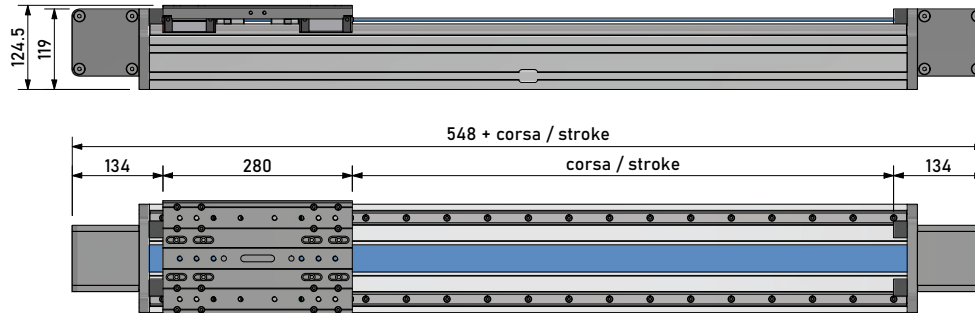

### DIMENSIONI CARRO / CARRIAGE DIMENSIONS

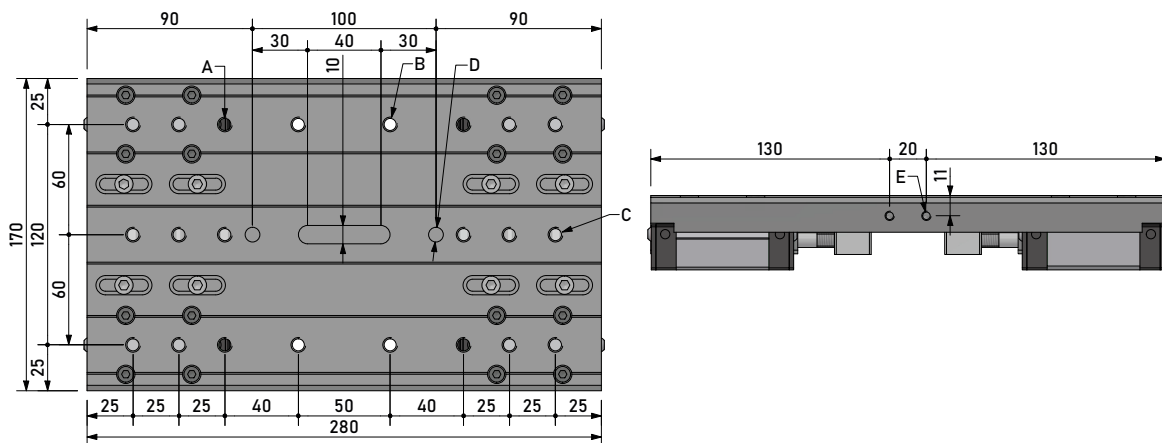

### DIMENSIONI TESTATA MOTORE / MOTOR HEAD DIMENSIONS

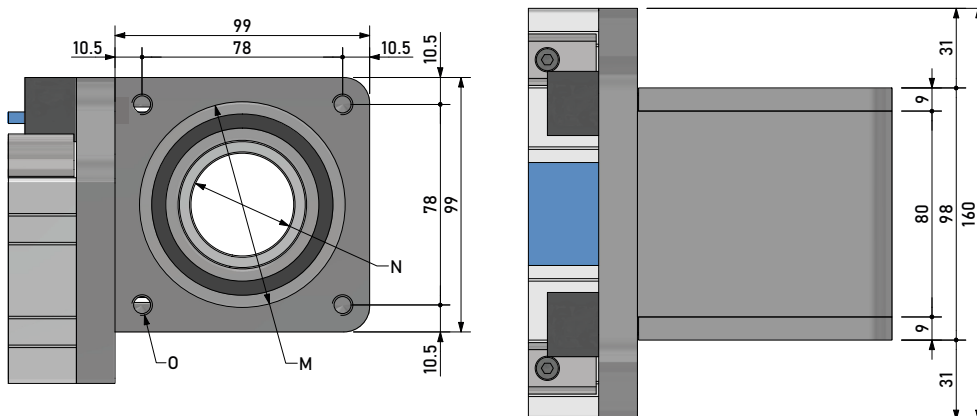

NOME / NAME	A	B	C	D	E	M	N	O
Ø - FILETTO / Ø - THREAD	12x M8	4x M8	6x M8	2x Ø8 H7	2x M5	Ø80 H7	Ø40 H7	4x M8
PROFONDITÀ / DEPTH	15	20	18	15	10	15	PASSANTE / THRU-HOLE	16