

HR-M200VI20

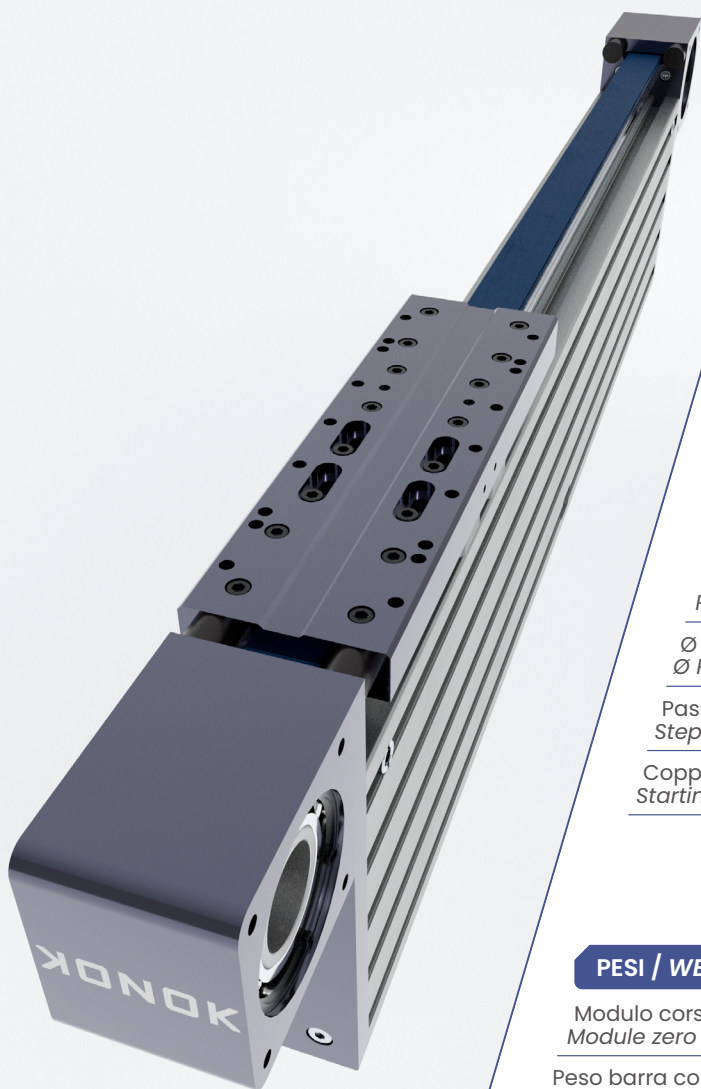

SPECIFICHE TECNICHE / TECHNICAL DATA

| | |
|---------------------------------------|--------------------------|
| Versione unità Type Unit | Monoguida Monorail |
| Sezione portante Structure Section | 200x80 |
| Dimensioni guide Rail Size | 20 |
| Cinghia Belt | AT10-32 |
| Velocità Speed | 4 (m/sec) |
| Accelerazione Acceleration | 30 (m/sec ²) |
| Ripetibilità Repeatability | 0.1 (mm) |

DATI PULEGGIA / PULLEY DATA

| | |
|---|------------|
| Puleggia Pulley | Z22 |
| Ø Primitivo puleggia Ø Pulley Primitive | 70.03 [mm] |
| Passo per giro puleggia Step for Pulley turn | 220 [mm] |
| Coppia a vuoto Starting Torque | 3.0 [Nm] |

PESI / WEIGHTS

| | |
|---|---------|
| Modulo corsa zero Module zero travel | 13 kg |
| Peso barra corsa zero Zero stroke bar weight | -- kg |
| Peso 100mm lineare Linear weight 100mm | 1.78 kg |
| Peso del carro Carriage weight | 2.5 kg |

CONDIZIONI DI ESERCIZIO CONSIGLIATE / RECOMMENDED OPERATING CONDITIONS

| | | | |
|------------------------------------|------------------|------------------|------------------|
| Momento dinamico Dynamic Moment | Mx 82 Nm | My 570 Nm | Mz 570 Nm |
| Forze statiche Static forces | Fy 2370 N | Fz 2370 N | |
| Carico a trazione Tensile load | Fx 2600 N | | |

* Il valore Fx si riferisce al carico applicabile alla puleggia, e non al valore di carico ammissibile dalla cinghia. Tale valore è calcolato sulla base del tipo di cinghia e del numero di denti della puleggia.
* The Fx value refers to the load applicable to the pulley, and not to the allowable load value of the belt. This value is calculated on the basis of the type of belt and the number of pulley teeth.

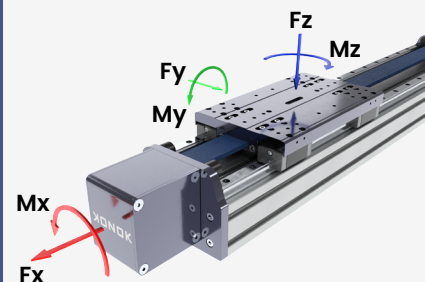

I valori dinamici indicati non corrispondono alle massime capacità di carico teoriche. Sono stati calcolati considerando fattori di sicurezza adatti alle automazioni industriali. In caso di sollecitazioni massime contemporanee si prega di contattare il servizio tecnico.
The dynamic values indicated do not correspond to the theoretical maximum load capacities. They have been calculated considering safety factors suitable for industrial automation. In case of simultaneous maximum stresses, please contact the technical service.

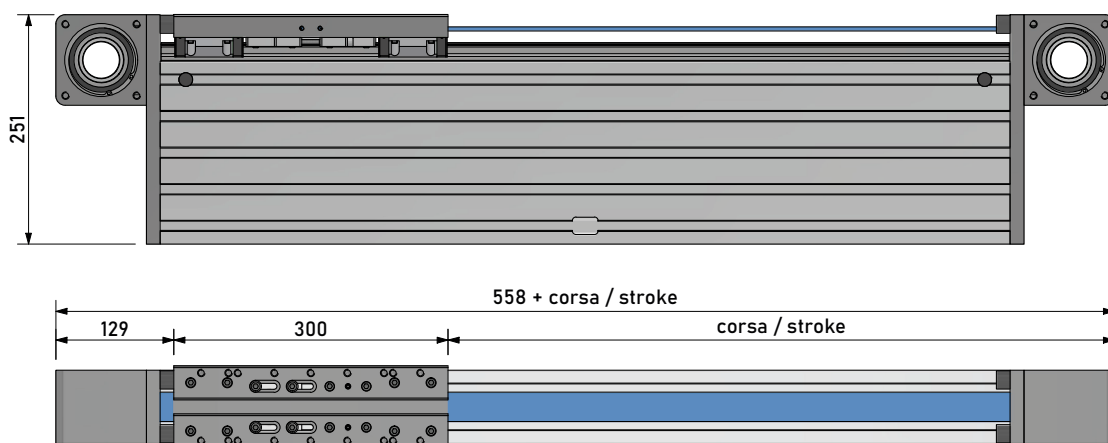

PAG. 168

SEZIONE PORTANTE / STRUCTURAL SECTION

| | | |
|---|---|------------------------|
| Momento d'inerzia Moment of inertia | Ix | 1789.8 cm ⁴ |
| Momento d'inerzia Moment of inertia | Iy | 353.1 cm ⁴ |
| Modulo resistenza flessione Flexural Modulus | Wx | 98.0 cm ⁴ |
| Modulo resistenza flessione Flexural Modulus | Wy | 179.0 cm ⁴ |
| Peso lineare Linear Weight | | 14.3 Kg/m |
| Tipo cava Hollow Type |  | 10-PG |

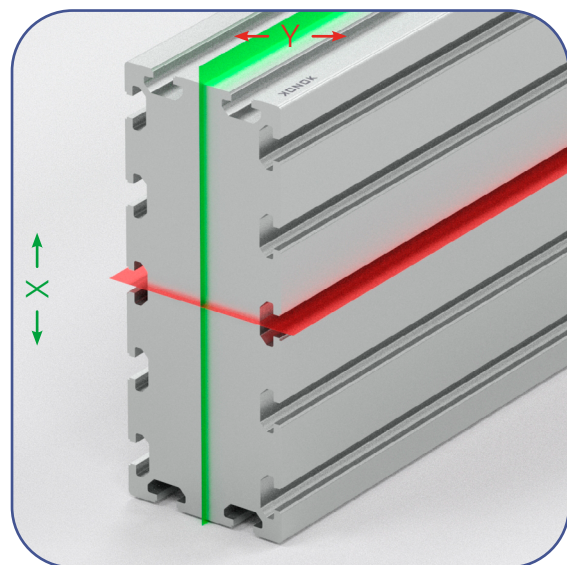

HR-M200VI20

DIMENSIONI / DIMENSIONS

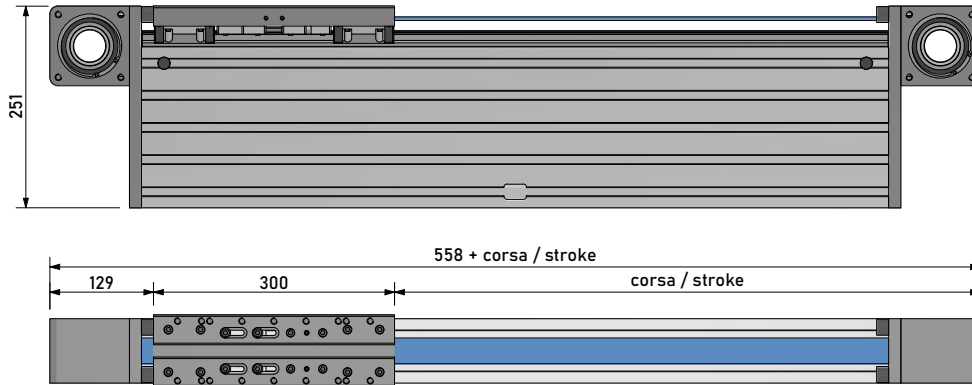

DIMENSIONI CARRO / CARRIAGE DIMENSIONS

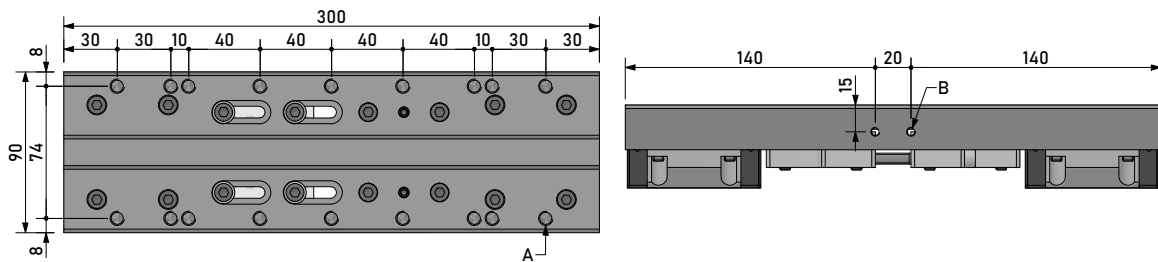

DIMENSIONI TESTATA MOTORE / MOTOR HEAD DIMENSIONS

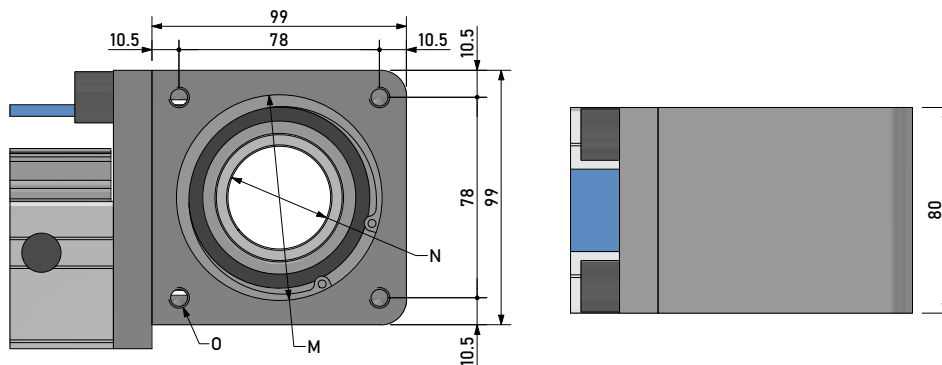

| NOME / NAME | A | B | M | N | O |
|--------------------------|--------|-------|--------|----------------------|-------|
| Ø - FILETTO / Ø - THREAD | 18x M8 | 2x M5 | Ø80 H7 | Ø40 H7 | 4x M8 |
| PROFONDITÀ / DEPTH | 20 | 15 | 2.5 | PASSANTE / THRU-HOLE | 16 |