

HR-K200VK25

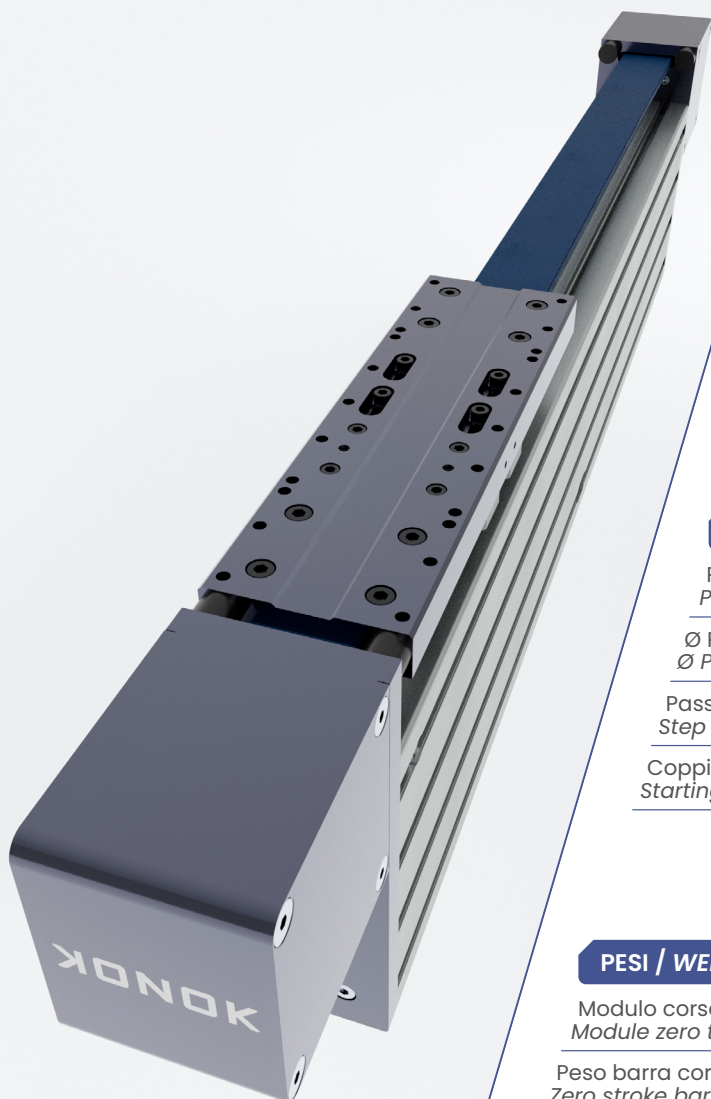

SPECIFICHE TECNICHE / TECHNICAL DATA

Versione unità Type Unit	Monoguida Monorail
Sezione portante Structure Section	200x100
Dimensioni guide Rail Size	25
Cinghia Belt	EAGLEM10-50
Velocità Speed	4 (m/sec)
Accelerazione Acceleration	30 (m/sec ²)
Ripetibilità Repeatability	0.1 (mm)

DATI PULEGGIA / PULLEY DATA

Puleggia Pulley	Z28
Ø Primitivo puleggia Ø Pulley Primitive	89.12 [mm]
Passo per giro puleggia Step for Pulley turn	280 [mm]
Coppia a vuoto Starting Torque	3.0 [Nm]

PESI / WEIGHTS

Modulo corsa zero Module zero travel	20.5 kg
Peso barra corsa zero Zero stroke bar weight	-- kg
Peso 100mm lineare Linear weight 100mm	2.25 kg
Peso del carro Carriage weight	3.3 kg

CONDIZIONI DI ESERCIZIO CONSIGLIATE / RECOMMENDED OPERATING CONDITIONS

Momento dinamico Dynamic Moment	Mx 136 Nm	My 1020 Nm	Mz 1020 Nm
Forze statiche Static forces	Fy 3496 N	Fz 3496 N	
Carico a trazione Tensile load	Fx 4300 N		

* Il valore Fx si riferisce al carico applicabile alla puleggia, e non al valore di carico ammissibile dalla cinghia. Tale valore è calcolato sulla base del tipo di cinghia e del numero di denti della puleggia.
* The Fx value refers to the load applicable to the pulley, and not to the allowable load value of the belt. This value is calculated on the basis of the type of belt and the number of pulley teeth.

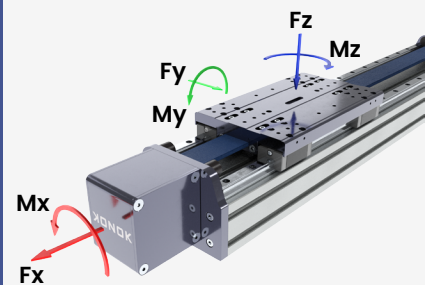

I valori dinamici indicati non corrispondono alle massime capacità di carico teoriche. Sono stati calcolati considerando fattori di sicurezza adatti alle automazioni industriali. In caso di sollecitazioni massime contemporanee si prega di contattare il servizio tecnico.
The dynamic values indicated do not correspond to the theoretical maximum load capacities. They have been calculated considering safety factors suitable for industrial automation. In case of simultaneous maximum stresses, please contact the technical service.

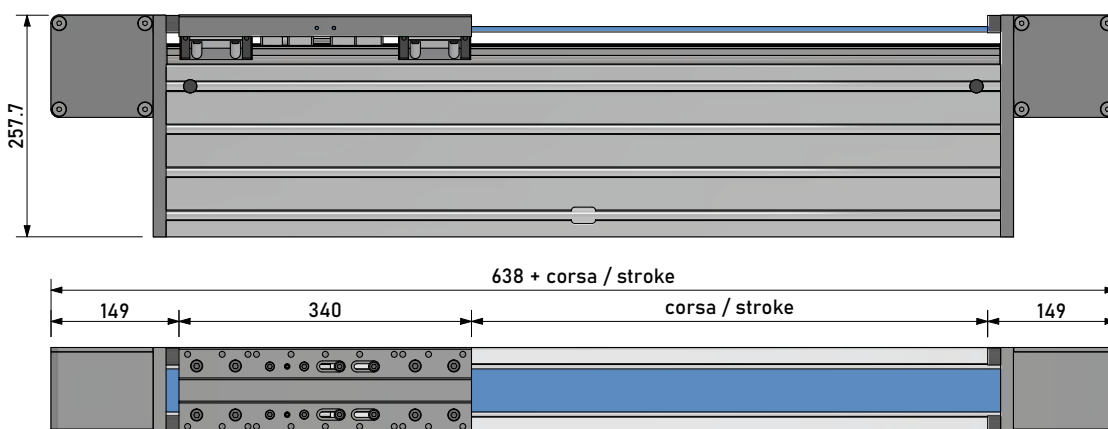

PAG. 172

SEZIONE PORTANTE / STRUCTURAL SECTION

Momento d'inerzia <i>Moment of inertia</i>	I_x	2725.7 cm ⁴
Momento d'inerzia <i>Moment of inertia</i>	I_y	791.8 cm ⁴
Modulo resistenza flessione <i>Flexural Modulus</i>	W_x	272.6 cm ⁴
Modulo resistenza flessione <i>Flexural Modulus</i>	W_y	158.4 cm ⁴
Peso lineare <i>Linear Weight</i>		17.7 Kg/m
Tipo cava <i>Hollow Type</i>		10-PG

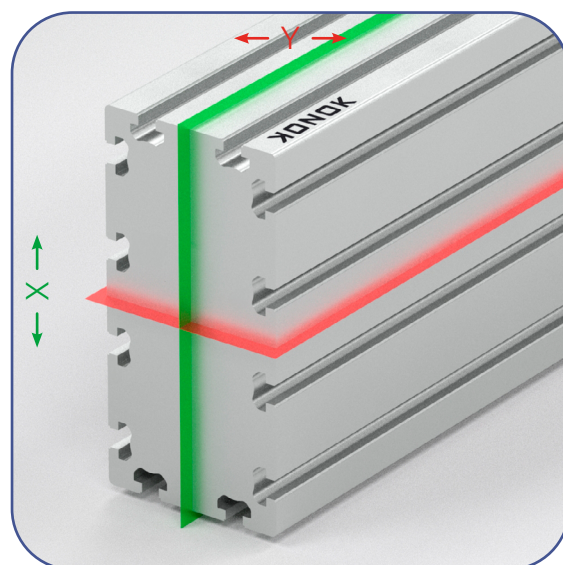

HR-K200VK25

DIMENSIONI / DIMENSIONS

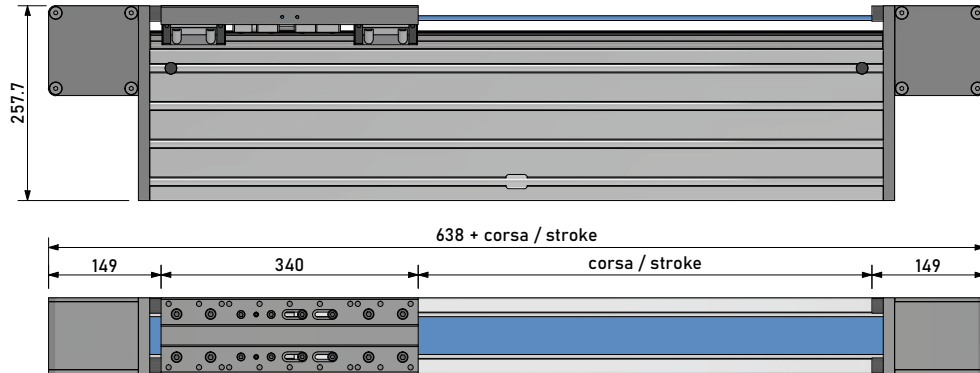

DIMENSIONI CARRO / CARRIAGE DIMENSIONS

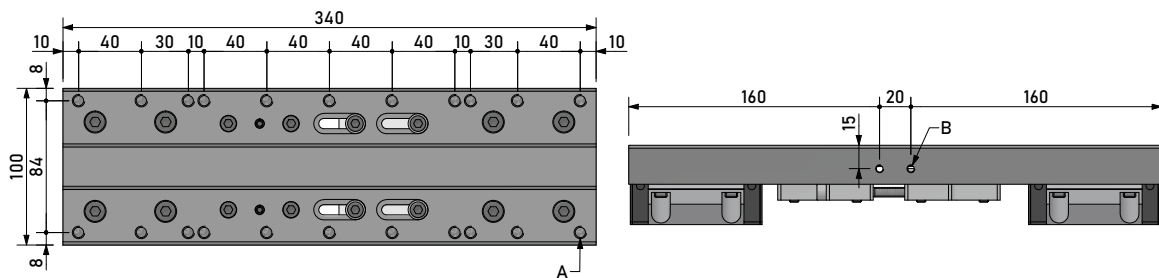

DIMENSIONI TESTATA MOTORE / MOTOR HEAD DIMENSIONS

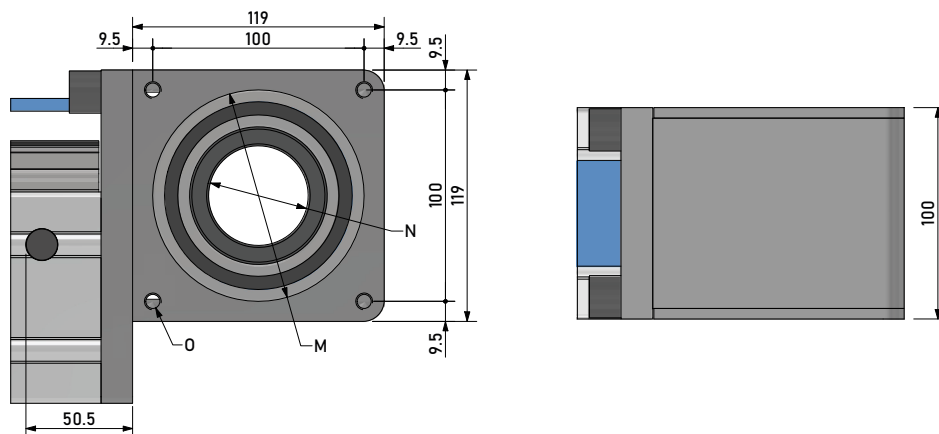

NOME / NAME	A	B	M	N	O
Ø - FILETTO / Ø - THREAD	22x M8	2x M5	Ø100 h7	Ø47 H7	4x M8
PROFONDITÀ / DEPTH	20	15	/	PASSANTE / THRU-HOLE	16
SPORGENZA / SPORGENZA	/	/	2	/	/